

# Third Generation EmDrive

Roger Shawyer

July 2017

## EmDrive Development Phases

- First Generation.** Original low thrust technology for in-orbit satellite applications. Reported to be operational in US and China.
- Second Generation.** High thrust, low acceleration, superconducting technology. Space and Marine applications. Under development in UK and US.
- Third Generation.** High thrust. High acceleration, superconducting technology. Theoretical work reported in US, China and UK. Aerospace applications including Launch Vehicles and Personal Air Vehicles.

## 3G EmDrive Theory

High Q superconducting cavities are subject to large Doppler Shifts when accelerated.

This can lead to the internal frequency being shifted outside the resonant bandwidth of the cavity over the time constant of the cavity.

The theory is mathematically described in the conference paper:

*The Dynamic Operation of a High Q Microwave Thruster*

*Roger Shawyer SPR Ltd*

*IAC 13. Beijing. September 2013.*

A method of compensating for the Doppler Shift and allowing useful levels of acceleration to be achieved, whilst retaining high Q and thus high thrust operation, is described in:

*Patent GB 2537119*

*Superconducting Microwave Radiation Thruster*

*Published October 2016.*

# 3G Thruster

Freq 1.5GHz  
LH2 cooled YBCO  
Thrust 1.54kN/kWm  
Acceleration compensation uses a stack of 2 Thrusters

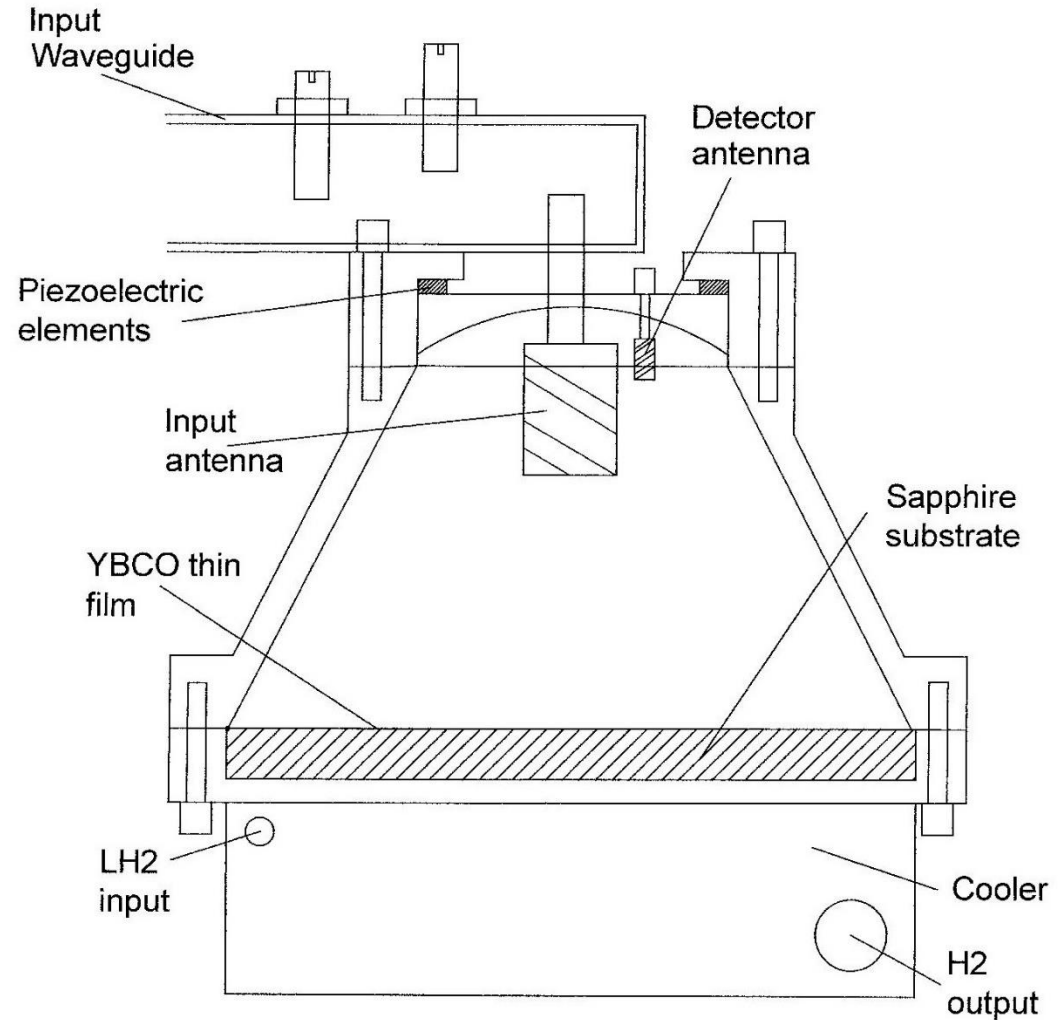

# 3G Launch Vehicle Demonstrator

Propulsion is based on a quad thrust platform, common to a number of aerospace applications.

Mass 701kg

Dimensions

L3.0m x W3.0m x H3.8m

8 Flight Thrusters

VTOL

Launcher provides launch to LEO, one orbit, and return to site

Payload 100kg

Altitude 250km

Velocity 7.8km/s

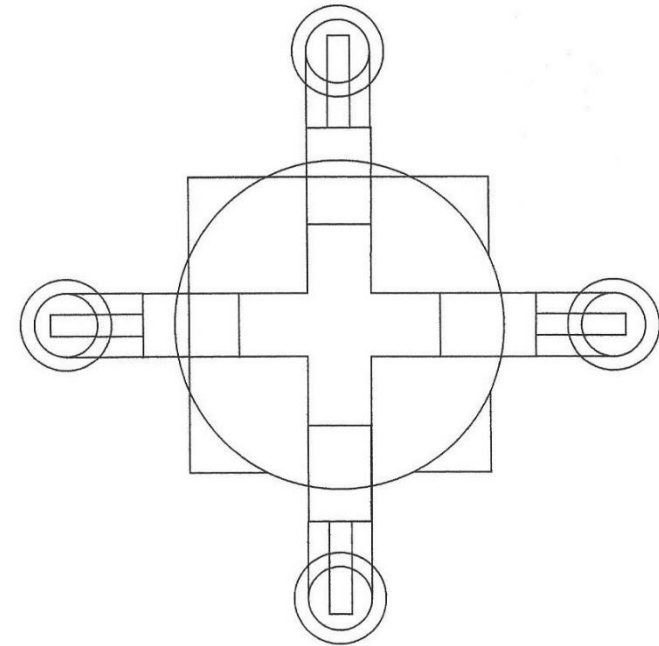
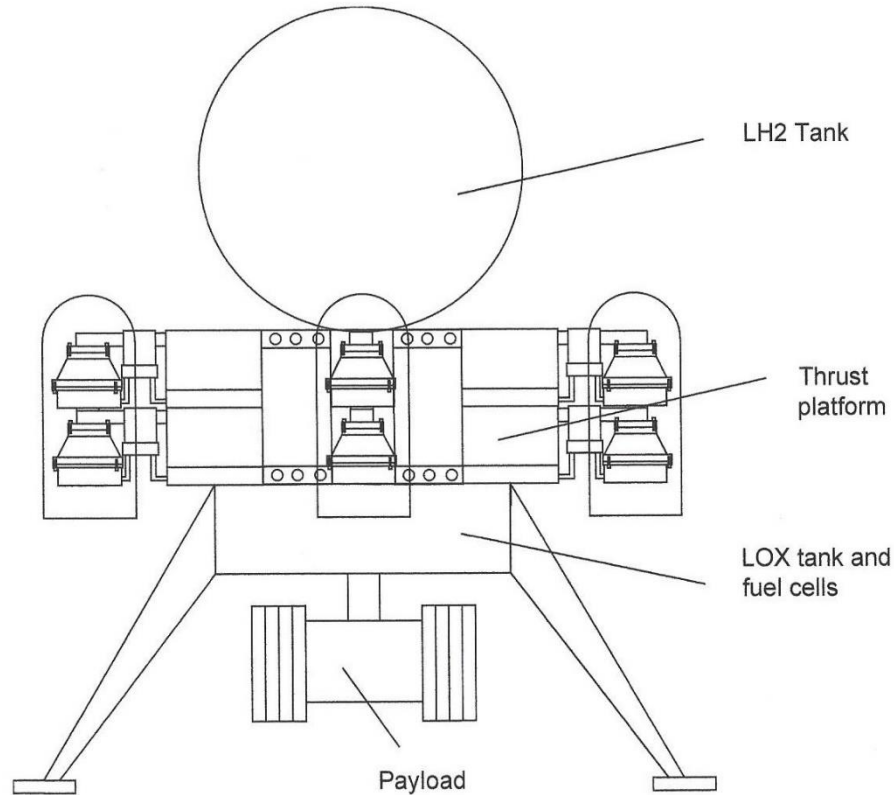

# EmDrive Personal Air Vehicle

Eight, 3G thrusters give multiple redundancy, allowing up to four to fail.

Stand-by LH2 tanks and batteries give 10 minute operation for any emergency landing, and a ballistic parachute is incorporated.

Simple pilot controls are based on flight proven Drone control software, with autonomous operation as an option.

EmDrive offers silent, reliable, solid-state propulsion with no moving parts.

Liquid Hydrogen (LH2) is a green renewable fuel, with water vapour as exhaust.

The PAV gives safe Urban Canyon operation.

Total LH2 volume 2,400 litres. Take-off Mass = 940kg

Maximum velocity = 230 km/hr Maximum acceleration 0.4g

Maximum Operating Time = 2.5 Hours

